

# Mail-In Voter Registration Form

★★★ District of Columbia  
Board of Elections and Ethics

**You can use this form to:**

- register to vote in the District of Columbia
- let us know that your name or address has changed
- register with a party or change parties

**To register to vote in D.C., you must:**

- be a U.S. citizen
- be a D.C. resident
- be at least 18 years old on or before the next election
- not be in jail for a felony conviction
- not have been judged "mentally incompetent" by a court of law
- not claim the right to vote anywhere outside D.C.

**Questions? Call 727-2525**

*Hearing-impaired people with TDD, call 639-8916*

**Información en español:** Si le interesa obtener este formulario en español, llame al 727-2525.

**Important!**

**Keep your voter record up-to-date!** If we do not have your current name or address, you might not be on the voter roll. If you are not on the voter roll, you will not be able to vote in the next election.

Use this form to send in your name or address change. If you are not sure if we have your current name or address, use this form, too. Or call 727-2525.

**To vote in a primary election, you must be registered with a party that holds a primary election—either the Democratic, Republican or D.C. Statehood Party.**

If you register with any other party, or with no party, you may vote only in general or special elections. Use this form if you want to register with a party or change parties (see box 8).

0-0976

Use pen—please print clearly

<b>1</b> Check one: <input type="checkbox"/> new registration <input type="checkbox"/> address change <input type="checkbox"/> party change <input type="checkbox"/> name change		Clerk Reg. Date	Registration No. <b>AB 0532788</b>
<b>2</b> Mr. Mrs. Miss Ms.	Last Name	First Name	Middle Name Suffix Jr. Sr. II III IV
<b>3</b> Address Where You Live		Circle One NE NW SE SW	Apartment Number Zip Code
<b>4</b> Address Where You Get Your Mail (if different from #3)			Zip Code
<b>5</b> Date of Birth	<b>6</b> Daytime Telephone Number(s)	<b>7</b> Social Security Number (optional)	
<b>8</b> Party Registration—check one box		<b>10</b> Voter Declaration—read and sign below	
<input type="checkbox"/> Democratic Party <input type="checkbox"/> Republican Party <input type="checkbox"/> D.C. Statehood Party <input type="checkbox"/> No Party (independent) <input type="checkbox"/> Other Party (write name below)		I swear or affirm that: • I am a U.S. citizen • I live in the District of Columbia at the address (#3) above • I will be at least 18 years old on or before the next election • I am not in jail on a felony conviction • I have not been judged "mentally incompetent" in a court of law • I do not claim the right to vote anywhere outside D.C.	
Name and Address on Last Voter Registration Name _____ Address _____ _____ _____ (If outside D.C., include county and state)		Signature _____ Date _____  <b>WARNING: If you sign this statement even though you know it is untrue, you can be convicted and fined up to \$10,000 and/or jailed for up to five years.</b>	

Fold on dotted lines, peel off tape, seal and mail

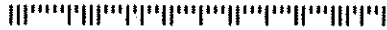

WASHINGTON, D.C. 20077-1219  
ROOM 4, DISTRICT BUILDING

DISTRICT OF COLUMBIA  
BOARD OF ELECTIONS & ETHICS

POSTAGE WILL BE PAID BY ADDRESSEE

FIRST CLASS PERMIT NO. 10978 WASHINGTON, D.C.

**BUSINESS REPLY MAIL**

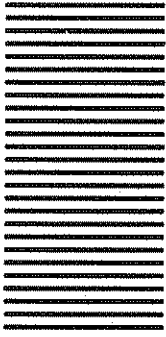

NO POSTAGE  
NECESSARY  
IF MAILED  
IN THE  
UNITED STATES



**Did you remember to:**

1. Write your full name, address and date of birth (in boxes 2, 3 and 5).
2. Sign and date the form (in box 10).

**Deadline:**

The voter registration deadline is 30 days before the next election. If you mail this form, it must be postmarked by that date. If you miss the deadline, you will not be registered in time to vote.

*If you are qualified and the information on your form is complete, we will add your name to the District's voter roll. We will then mail you a voter card. This card will tell you where to vote.*

**Questions? Call 727-2525**

*Hearing-impaired people with TDD, call 639-8916*



District of Columbia Board of Elections and Ethics



By Mail

UTAH ELECTION REGISTRATION FORM

1. FULL NAME (PRINT LEGIBLE) \_\_\_\_\_ Last \_\_\_\_\_ First \_\_\_\_\_ Middle \_\_\_\_\_

2. STREET ADDRESS \_\_\_\_\_ House Number \_\_\_\_\_ Direction of Principle Place of Residence (N,S,E,W) \_\_\_\_\_ Street Name \_\_\_\_\_ Type (St, Dr, Ln, Av, etc.) \_\_\_\_\_ Apt # \_\_\_\_\_  
CITY \_\_\_\_\_ UTAH, ZIP \_\_\_\_\_

3. MAILING ADDRESS \_\_\_\_\_  
if Different (include post office box, city, town or other designation for receiving your mail)

4. DATE OF BIRTH \_\_\_\_\_ MO \_\_\_\_\_ DAY \_\_\_\_\_ YR \_\_\_\_\_

7. DISABLED OR HANDICAPPED Yes \_\_\_\_\_ No \_\_\_\_\_

5. PLACE OF BIRTH \_\_\_\_\_ State or Foreign Country \_\_\_\_\_ 8. U.S. CITIZEN Yes \_\_\_\_\_ No \_\_\_\_\_

6. TELEPHONE NUMBER \_\_\_\_\_ (Home) \_\_\_\_\_ (Unless Unlisted) (Work) \_\_\_\_\_

9. Previous record of Voter Registration:  NEVER REGISTERED TO VOTE

MY NAME WAS LISTED AS \_\_\_\_\_ Maiden or former name used

LAST FORMER ADDRESS LISTED ON VOTER RECORDS: \_\_\_\_\_

CITY \_\_\_\_\_ COUNTY \_\_\_\_\_ STATE \_\_\_\_\_ ZIP CODE \_\_\_\_\_

VOTING DISTRICT OR PRECINCT (if known) \_\_\_\_\_

*I do swear (or affirm), subject to penalty of law or false statements, that the information contained in this form is true, and that I am a citizen of the United States and a resident of the State of Utah, residing at the above address. I will be at least 18 years old and will have resided in Utah for 30 days immediately preceding the next election to be held \_\_\_\_\_ 19 \_\_\_\_\_*

10. TODAY'S DATE \_\_\_\_\_ MO \_\_\_\_\_ DAY \_\_\_\_\_ YR \_\_\_\_\_

11. SIGNED & SWORN \_\_\_\_\_ Voter Applicant's Signature

**NOTICE: In order to vote, your name must appear in the Official Register Book.**

REGISTRATION AGENTS USE ONLY

VOTING DISTRICT NUMBER \_\_\_\_\_

(

(

(

## **CHAPTER 4**

### **AGENCY REGISTRATION PROVISIONS**

---

The National Voter Registration Act requires that individuals be given the opportunity to register to vote (or to change their voter registration address) in elections for federal office when applying for (or receiving) services or assistance:

- at any office in the State that provides public assistance [Section 7(a)(2)(A)]
- at or through any office in the State that provides State-funded programs primarily engaged in providing services to persons with disabilities [Section 7(a)(2)(B) with Section 7(a)(4)(B)]
- at certain other offices designated by the State [Section 7(a)(3)(A)], and
- at Armed Forces recruitment offices [Section 7(c)(1)].

Individuals must be provided this opportunity not only at the time of their original application for services, but also when filing any recertification, renewal, or change of address relating to such services [Section 7(a)(6)(A)].

Those who decline to register to vote must do so in writing or by not checking a box on a form that contains wording specified in the Act [Section 7(a)(6)(A) and (B)]. No information regarding a person's declination to register may be used for any purpose other than voter registration [Section 7(a)(7)].

Similarly, if an individual does register to vote, the particular agency at which the applicant submits a voter registration application may not be publicly disclosed [Sections 8(a)(6) and 8(i)(1)].

Agencies providing voter registration services must offer the same degree of assistance, including bilingual assistance where necessary, to individuals in completing a voter registration form as they offer to individuals in completing the agency's own forms, unless the applicant refuses such assistance [Sections 7(a)(4)(A)(ii) and 7(a)(6)(C)].

Moreover, the person who provides such services in the agency is prohibited from:

- seeking to influence an applicant's party preference or party registration
- displaying any such political preference or party allegiance
- making any statement or taking any action whose purpose or effect is to discourage the applicant from registering to vote, or

- making any statement or taking any action whose purpose or effect is to lead the applicant to believe that a decision whether or not to register has any bearing on the availability of services or benefits [Section 7(a)(5)].

## **IMPORTANT ISSUES IN AGENCY REGISTRATION**

---

There are several important issues States will want to consider in designing their agency registration forms and procedures:

- selecting agencies to serve as voter registration sites
- the format and content of the form to be used in applying for voter registration in an agency
- the format and content of the declination form, or portion of the form, to be used for declining to apply for voter registration in an agency
- the transmittal of voter registration applications from agency offices to the appropriate election official, and
- administering a voter registration program.

### **Selecting Agencies as Voter Registration Sites**

The Act mandates four types of offices to be designated as voter registration sites:

- all public assistance offices
- offices that operate State-funded programs primarily engaged in providing services to persons with disabilities
- other designated offices, and
- Armed Forces recruitment offices.

#### ***Public Assistance Offices***

The Act requires that “all offices in the State that provide public assistance” be designated as voter registration agencies [Section 7(a)(2)(A)].

There were some differences between the House and the Senate regarding this issue in general, and specifically which agencies would be considered mandatory. The Conference Committee therefore delineated the minimum of agencies it concluded were to be encompassed. “By public assistance agencies, we intend to include those State agencies in each State that administer or provide services under”:

- the food stamp program
- the Medicaid program
- the Special Supplemental Food Program for Women, Infants, and Children Program (WIC)
- the Aid to Families With Dependent Children Program (AFDC) [Conf Stat, Section 7, page 19].

States must decide for themselves what other of their offices meet the definition of “public assistance offices.”

***Offices that Operate State-funded Programs Primarily Engaged in Providing Services to Persons with Disabilities***

In addition to the above programs, the Act mandates the inclusion of “all offices in the State that provide State-funded programs primarily engaged in providing services to persons with disabilities” [Section 7(a)(2)(B)]. This section of the Act is intended to encompass not only those with physical disabilities, but also people with cognitive disabilities, and people with mental illness or mental disabilities — State law permitting.

It is impossible to delineate which agencies those might include since States vary widely in how they provide such services. “While it would include vocational rehabilitation offices, it would also extend to many other agencies that have contact...with persons with disabilities, such as, but not limited to those agencies which provide transportation, job training, education counseling, rehabilitation or independent living services” [Hse. Rpt., Section 7, page 12]. But each State will have to identify for itself the specific public or private agencies within their own State that fit the definition. (For assistance, States might want to contact their Governor’s designee on the Americans with Disabilities Act, State Developmental Disabilities Council, Governor’s Committee on Disabilities, State Independent Living Council or Section 504 Coordinator).

It is very important to note, however, that the Act requires that if such an agency “provides services to a person with a disability at the person’s home, the agency shall provide [voter registration services] at the person’s home” [Section 7(a)(4)(B)].

***Other Offices***

The Act further requires States to “designate other offices within the State as voter registration agencies” [Section 7(a)(3)(A)]. Although required to designate at least some other agencies, States are given considerable latitude in deciding which agencies those might be. The Act merely says that they *may* include:

- public libraries
- public schools

- offices of city and county clerks (including marriage license bureaus)
- hunting and fishing license bureaus
- government revenue offices
- unemployment compensation offices
- other offices that provide services to those with disabilities, and
- federal and nongovernmental offices, with the agreement of those offices [Section 7(a)(3)(B)].

Nothing in the Act, however, prohibits States from designating still other agencies according to their own needs and preferences.

Should any of these “designated” agencies provide public assistance, they, like those agencies referred to in Section 7(a)(2)(A), must provide the applicant with a means for executing a written declination and must also provide help in filling out the voter registration application to those individuals requesting such help [Section 7(a)(6)(A&B)].

(NOTE: The Act requires all departments, agencies, and other entities of the executive branch of the federal government to cooperate with the States in carrying out agency registration to the greatest extent practicable [Section 7(b)]. States, however, bear the responsibility of negotiating any such arrangements directly with the appropriate federal agency.)

#### ***Armed Forces Recruitment Offices***

Finally, the Act requires each State and the Secretary of Defense to jointly “develop and implement procedures for persons to apply to register to vote at recruitment offices of the Armed Services of the United States” [Section 7(c)].

The Federal Voting Assistance Program, acting as the designee of the Secretary of Defense, will work with the States in implementing this section of the Act. The address and telephone number of the Federal Voting Assistance Program are provided in Appendix E.

#### **The Form to Be Used in Applying for Voter Registration in an Agency**

The Act requires that designated agencies distribute to each applicant a mail registration form that is either the national mail registration form, or “the office’s own form if it is equivalent to” the national mail registration form, unless the applicant declines in writing to register to vote [Section 7(a)(4)(a)(i) with Section 7(a)(6)(A)].

Two important aspects of the form to be used in agency registration are the format of the form, and the content of the form.

### ***The Format of the Agency Registration Form***

With regard to prescribing their agency registration form, States would appear to have one of three options:

- the national mail registration form
- the State mail registration form (which could, arguably, be declared the “office’s own form”), or
- the agency’s own unique mail registration form if it meets the criteria set out for the national mail registration form.

One available option is using the *national mail registration form* in agency registration programs. The national form, as explained in Chapter 3, however, is likely to contain data elements that do not pertain to all States — such as political party preference. Moreover, the national form is likely to be a booklet in order to accommodate, among other things, the different State qualifications for voting and different mailing addresses for the form. For these reasons, States may not find this option to be the most efficient or effective.

A second option for an agency registration program is the *State mail registration form* which, as noted in Chapter 3, must be equivalent to the national form in terms of content — except that it can be State specific with regard to required data elements and voter qualifications. An additional advantage to the State form is that it can be pre-addressed to the appropriate State or local election official.

A third option is the *agency’s own unique mail voter registration form* which would, presumably, be nearly identical to the State mail registration form. The principal advantage of this choice is that such a form could become a perforated or pressure sensitive part of the agency’s own form(s), thus facilitating the process for both applicants and agency clerks alike. It is important, however, that any such form not clearly identify the particular agency or office in which the applicant registered (for further discussion, see pages 4-12, and 7-3). This is significant because in most States voter registration forms are public documents whereas, under the terms of this Act, the particular agency at which an applicant submits a voter registration application may not be publicly disclosed [Section 8(i)(1)].

### ***The Content of the Agency Registration Form***

The content of whatever mail registration form is used in the agency registration program must meet the same requirements as the national mail registration form [Section 7(a)(6)(A)(ii)]. See Chapter 3 for a full discussion of these aspects of the national mail registration form. It is also true, however, that State mail registration forms must be “equivalent” to the national mail registration form [Section 6(a)(2)] except that State mail registration forms can be more specific — containing only those items required in that State. (Hence, the advantage of using the State mail registration form or a combined agency form in State agencies).

## Declining to Apply for Voter Registration in an Agency

The Act requires that participating agencies provide mail voter registration forms to applicants “unless the applicant, in writing, declines to register to vote” [Section 7(a)(6)(A)]. Indeed, the Act specifies some of the language that must appear as part of the declination form [Section 7(a)(6)(B)]. Further, the Act declares that “No information relating to a declination to register to vote in connection with an application made at an [agency] office...may be used for any purpose other than voter registration” [Section 7(a)(7)].

There are three important aspects to be considered regarding a declination to apply for voter registration in an agency:

- the *content* of the declination
- the *format* of the declination, and
- the *confidentiality* of the declination.

### *The Content of the Declination*

The Act specifically requires the following elements as part of the declination.

- “If you are not registered to vote where you live now, would you like to apply to register to vote here today?”

(and if the agency provides public assistance)

- “Applying to register or declining to register to vote will not affect the amount of assistance that you will be provided by this agency.”
- “IF YOU DO NOT CHECK EITHER BOX, YOU WILL BE CONSIDERED TO HAVE DECIDED NOT TO REGISTER TO VOTE AT THIS TIME.” (with “yes” and “no” boxes being provided)
- “If you would like help filling out the voter registration application form, we will help you. The decision whether to seek or accept help is yours. You may fill out the application form in private.”, and
- “If you believe that someone has interfered with your right to register or to decline to register to vote, your right to privacy in deciding whether to register or in applying to register to vote, or your right to choose your own political party or other political preference, you may file a complaint with \_\_\_\_\_ (the blank being filled by the name, address, and phone number of the appropriate official to whom such a complaint should be addressed).

If the declination is contained on a separate form, States are required to add two others — parallel to those required on the motor voter registration application:

- a statement that if the applicant declines to register to vote, that this decision will remain confidential and be used only for voter registration purposes, and
- a statement that if the applicant does register to vote, information regarding the office to which the application was submitted will remain confidential, again to be used only for voter registration purposes.

And finally, States will no doubt want to obtain, for record keeping purposes:

- the name of the applicant
- the signature of the applicant (or declinee), and
- the date.

### *The Format of the Declination*

By its nature, this affirmation or declination opportunity is the first voter registration question that applicants will be presented when they are applying for other services in public or private agencies. This declination lends itself, then, to being included in the other forms being completed by applicants — as an integral part of the agency's own form(s), or as a separate form.

As a practical matter, States should consider designating the chief State election official as the person to whom applicants should address any complaints — including, where possible, a toll free telephone number for the purpose.

States should also consider, as a thoughtful courtesy, perforating the bottom portion of the declination so that applicants can remove and retain the procedures for filing a complaint.

### *The Confidentiality of the Declination*

Although the Act does not specifically require that the declination be retained, States may nevertheless want to do so in order to maintain an audit trail, to ensure evidence should allegations of wrongdoing arise, and for the benefit of the agencies themselves.

States will want to decide who should maintain the records of agency declinations to register — whether the agency office or the election office. Nothing in the law prohibits or requires that information regarding declinations be forwarded to the election office. In order to minimize the transmittal burden on agency offices, such information might well be kept by the participating agencies — provided that it is held confidential and for two years pursuant to Sections 7(a)(7) and 8(i)(1) of the Act, and also provided that proper consideration be given to maintaining the confidentiality of individual health records in those agencies where such information is protected by law.

These confidentiality provisions are an essential component of agency voter registration procedures given the potential chilling effect public disclosure would have

for people registering to vote in, for example, a local Community Mental Health Center or in the office of the local provider of services for people with AIDS.

### **The Transmittal of Voter Registration Applications from Agency Offices to the Appropriate Election Official**

There are two ways in which agency voter registration applications can be transmitted to the appropriate election official, either:

- by the agency itself, or else
- directly by the applicant.

“An applicant may, if he or she chooses, mail the voter registration application directly to the appropriate State election official rather than returning it to the agency for transmittal. The agency providing voter registration services is prohibited from requiring a registrant to mail the form, and must accept it and forward it to the appropriate registration official if turned in by the applicant. The agency must provide regular, visible means for collecting registration application forms” [Hse. Rpt., Section 7, page 13].

If applicants submit voter registration applications to the agency, then the Act requires that agency authorities transmit them to the appropriate election official within ten (10) days after acceptance, or, if accepted within five (5) days before the close of registration, within five (5) days of acceptance [Section 7(d)].

The Act appears, however, to permit election officials to assume an active role in the forms distribution and collection process. (When the various agencies use separate voter registration forms). Some local election officials, in fact, might prefer to send a weekly courier to collect all the forms completed in the previous week and to resupply the agency's stock.

States where social service agency jurisdictions are not coterminous with election jurisdictions (or where individuals may apply for benefits or services at any agency office in the State) face a different challenge.

In some cases, States may prefer to have the agency offices sort completed voter registration forms by election jurisdictions — using postage paid envelopes or pouches that are then forwarded to the appropriate local election officials in those jurisdictions.

In other cases, States may prefer to have some or all voter registration applications forwarded to a central State election authority for sorting and re-routing to the appropriate local election officials.

Nothing in the Act would appear to prohibit any of these procedures provided that such voter registration applications are received by the local election official within the ten or five day period prescribed by the Act or else are still accepted by the local

election official even though they were received, by virtue of the State's procedure, after the ten or five day period prescribed by the Act.

### **Administering an Agency Voter Registration Program**

With regard to administering a successful agency voter registration program, the Federal Election Commission has available a free publication entitled *Innovations in Election Administration 5: Agency Voter Registration Programs* summarizing the experiences of States that operated some type of agency registration program prior to the passage of the NVRA — how they work, problems they have encountered, recommended practices, and the like.

Three important aspects of administering an agency voter registration program that warrant consideration here are:

- the need to appoint someone in each agency office to be in charge of and responsible for voter registration activities
- the need to train all agency employees involved with voter registration, and
- the accountability of agency voter registration forms.

#### ***Putting Someone in Charge***

Research suggests that a principal ingredient of a successful agency registration program is the appointment of someone in each agency office to be in charge of, responsible for, and enthusiastic about all voter registration activities — ensuring an adequate supply of forms, monitoring voter registration activities, training new employees, resolving questions and problems that arise in coordination with State or local election officials, and the like. Such a task need not be full time, but it must be on going.

#### ***Training Agency Employees***

A second ingredient to a successful agency registration program is the adequate training of all agency employees involved with voter registration — how to ensure that voter registration forms are completed and signed correctly, how to offer and provide assistance to registrants, and the like. After an initial training of all current employees, the training of new employees can be assumed by the agency person appointed to be in charge of the program.

#### ***The Accountability of Agency Registration Forms***

To monitor the effectiveness of agency registration programs, many jurisdictions have found it useful to account for the number of registration applications that are received from the various agency offices. And such a procedure gathers importance in light of the record keeping and reporting requirements of the Act (see Chapter 7 below).

The monitoring of applications depends largely on what form the agency uses.

If agencies use the State mail registration form as their application, then election officials might consider printing or subsequently stamping mail registration forms with sequential numbers. Sequentially numbering mail registration forms and distributing them in numbered batches to agency offices provides a basis for monitoring the process without divulging to the public the specific agency in which any particular applicant registered. (See also the discussion of the accountability of mail registration forms under Chapter 3 and the accountability of motor voter registration forms under Chapter 2).

If the voter registration application is on a *distinctive* agency form (such as a combined form or a computer generated form), then the task of monitoring incoming applications from various agency offices is greatly simplified. However, if original voter registration documents are a matter of public record, then there might be confidentiality problems in light of the Act's prohibition on publicly disclosing "the identity of a voter registration agency through which any particular voter is registered" [Section 8(i)(1)].

Challenges also arise if agencies use either the national mail registration form or the agency's own version of the State mail registration form even if it is identical to the State form (since sequentially numbering these might prove difficult).

Although it may prove possible to code the types of forms described in the previous two paragraphs (using either numbers or symbols), election officials would want to be sure to keep the codes confidential and perhaps even to mask the code with ink after it has been received, counted, and processed.

Failing the use of either sequential numbers or codes, election officials might have to count batches of applications as they are received from each participating agency.

**VOTER REGISTRATION LIST MAINTENANCE OPTIONS UNDER THE NVRA**

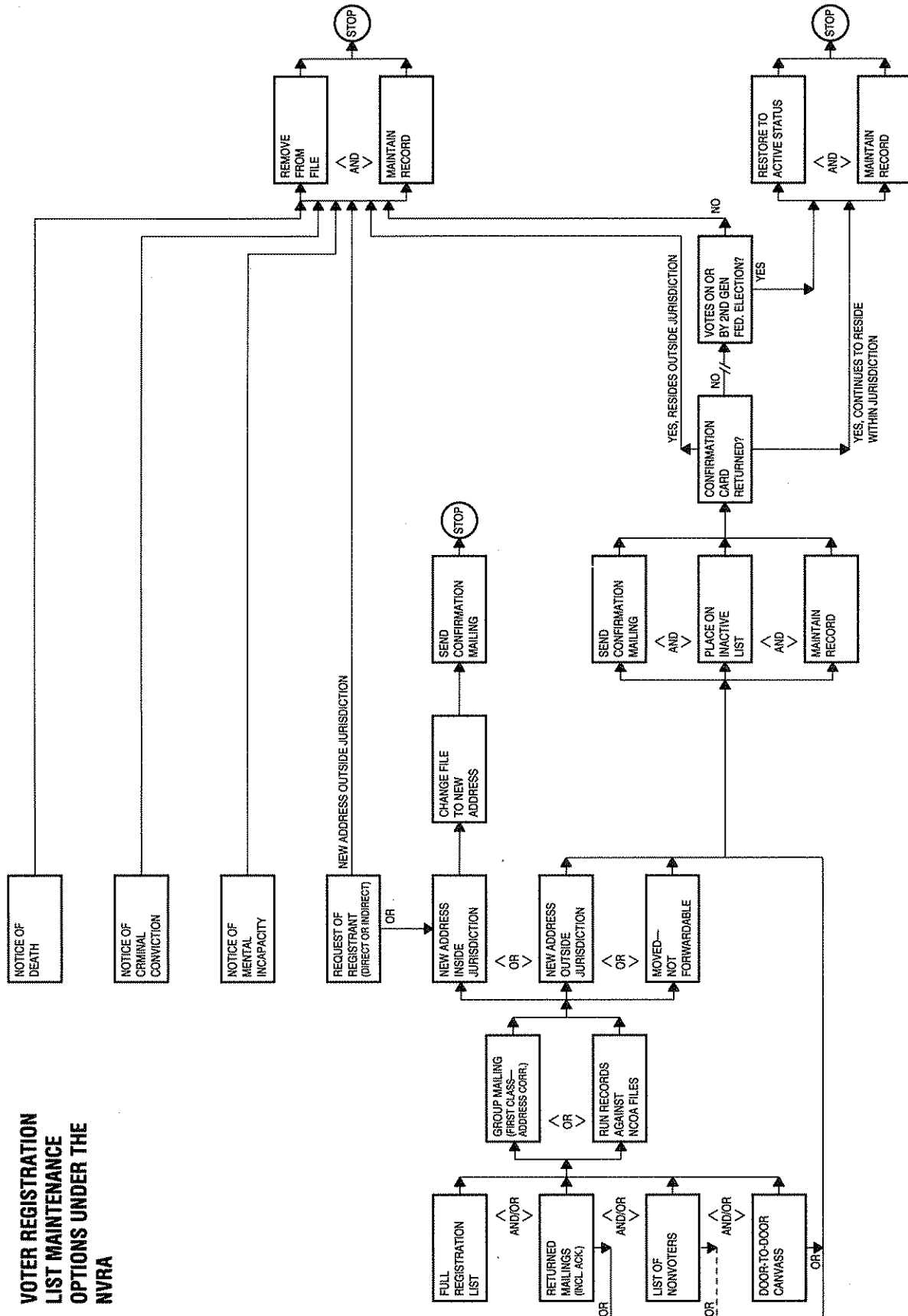



## **CHAPTER 5 - VOTER REGISTRATION LIST MAINTENANCE PROVISIONS**

---

The National Voter Registration Act contains several features that will fundamentally alter the way voter registration lists are maintained in most jurisdictions. These features include:

- a slight change in the date by which valid voter registration applications must be accepted by the registrar [Section 8(a)(1)]
- a requirement that registrars “send notice to each applicant of the disposition of the application” [Section 8(a)(2)]
- a change (for most jurisdictions) in the rules for removing individual names from the voter registration list [Sections 8(a)(3) and (4), Section 8(b)(2), and Sections 8(c) and 8(d)]
- a change (for most jurisdictions) in the rules for changing a registrant’s address information [Sections 8(c), 8(d), and 8(f)], and
- a requirement that States “conduct a general program” the purpose of which is “to protect the integrity of the electoral process by ensuring the maintenance of an accurate and current voter registration roll for elections for Federal office” [Sections 8(a)(4) and 8(b)].

### **IMPORTANT ISSUES IN VOTER REGISTRATION LIST MAINTENANCE**

---

The voter registration list maintenance requirements of the Act are fairly complex but permit the States considerable latitude in designing appropriate procedures. In doing so, there are important issues to consider:

- the date by which valid voter registration applications must be accepted
- the rules for removing names from the voter registration list
- the rule for changing a registrant’s address information, and
- the administration of the file maintenance program.

### **The Date By Which Valid Voter Registration Applications Must Be Accepted**

Most election offices currently accept and process voter registration applications up until their registration deadline. A few, as in California, accept mail registration applications for a few days after the deadline. States will need to revise these practices because the Act effectively applies the State's voter registration deadline (or the Act's 30 days before the election deadline, whichever is later) to when the form was submitted by the applicant rather than to when it is received by the election office.

The Act permits motor vehicle and agency offices up to five days to transmit to the election office any applications they receive on the last day of voter registration. (See the "Transmittal of Forms" portion of Chapters 2 and 4). Therefore, election offices must accept and process motor voter and agency voter registration applications up until at least five (5) days *past* the deadline for registration [Sections 8(a)(1)(A) and (C) along with Sections 5(e), and 7(d)].

The Act also requires election offices to accept and process mailed voter registration applications that are postmarked not later than the State's voter registration deadline (or the Act's 30 days before the election deadline, whichever is later) [Section 8(a)(1)(B)]. (See the "Transmittal of Forms" portion of Chapter 3 above).

As a practical matter, however, postmarks are not always applied by the Postal Service. And even when they are, they are not always readable. States may therefore want to consider accepting "any voter registration application that is postmarked not later than the deadline for voter registration or else is received in the mail not later than five days after the deadline for voter registration." Such an arrangement yields a single deadline for receiving *all* registration applications except those that are clearly postmarked before the close of registration but seriously delayed in the mails.

States might also want to establish rules and procedures to be followed in the event that motor voter or agency applications are, for some reason, *not* transmitted to the appropriate election official within the legal time frame.

### **The Rules for Removing Names from the Voter Registration List**

The NVRA *prohibits* removing the names of any individuals from the voter registration list solely for:

- **failure to vote** [Section 8(b)(2)], or
- **change of address** to another location **within the registrar's jurisdiction** (even if they fail to notify the registrar of the move) [Section 8(f)].

The Act *permits*, however, removing the names of individuals:

- upon **the request of the registrant** [Section 8(a)(3)(A)]
- for **mental incapacity** (as provided in State law) [Section 8(a)(3)(B)], or
- upon **criminal conviction** (as provided in State law) [Section 8(a)(3)(B)]

The Act also *requires* States to conduct a general program that makes a reasonable effort to remove the names of ineligible voters:

- upon their **death** [Section 8(a)(4)(A)]
- upon their **written confirmation of a change of address** to a location **outside the registrar's jurisdiction** [Sections 8(a)(4)(B) and 8(d)(1)(A)], and
- upon their **failure to respond to certain confirmation mailings and their failure to offer to vote in any election within two subsequent general federal elections** [Sections 8(a)(4)(B) and 8(d)(1)(B)].

#### *No Removal for Failure to Vote*

Although most jurisdictions currently remove the names of individuals from the voter registration list after their failure to vote within a specified time frame, the NVRA prohibits this practice [Section 8(b)(2)]. It does so in accordance with "an underlying purpose of the Act; that once registered, a voter should remain on the list of voters so long as the individual remains eligible to vote in that jurisdiction" [Hse. Rpt., Section 8, page 18].

#### *No Removal for Change of Address within the Registrar's Jurisdiction*

For exactly the same reason as quoted above, the Act prohibits removing names of individuals from the voter registration list simply because they changed residences *within* the registrar's jurisdiction [Section 8(f)]. If such a change of address comes to the attention of the registrar, the registrar may proceed in accordance with the "rules for changing a registrant's address" described below in this Chapter. If such a change of address does not come to the attention of the registrar, then the place and manner in which the individual votes is described in Chapter 6 on fail-safe voting procedures.

#### *Removal by Request of the Registrant*

Individuals may request that their names be removed from the voter registration list. The Act permits States to honor such requests [Section 8(a)(3)(A)]. It is also important to note that "A 'request' by a registrant would include actions that result in the registrant being registered at a new address, such as registering in another jurisdiction or providing a change-of-address notice through the driver's license process that updates the voter registration" [Hse. Rpt., Section 8, page 14]. (See also The Format and Content of the Form to be Used in the Driver's License Change of Address Process in Chapter 2.)

***Removal for Mental Incapacity***

Although the Act permits removing the names of individuals from the voter registration list by reason of mental incapacity, it does not define “mental incapacity.” Nor does it describe the process through which the registrar is to be informed of such a development. Instead it defers to State law [Section 8(a)(3)(B)]. States that have such provisions may want to take this opportunity to establish procedures whereby registrars are systematically informed of any declarations of mental incapacity — either directly or, perhaps more practicably, through the chief State election official. Research suggests that States with the most effective programs require the agencies responsible for maintaining records of declarations of incompetence (e.g.; clerks of court, district courts, etc.) to report on a scheduled basis (usually monthly) rather than an “as occurs” basis. The reports are made to both the local registration official and the State election official. The State election official, in turn, disseminates the information to the local jurisdiction for review and cross check against reports received from local agencies. State officials may either identify incompetency declarations by address and notify the appropriate official or send the entire report to all local jurisdictions. (See also that portion of Chapter 1 regarding the role of the chief State election official).

***Removal for Criminal Conviction***

The Act permits removing names of individuals from the voter registration list for reason of criminal conviction, but once again defers to State law [Section 8(a)(3)(B)].

To assist States that have such provisions, the Act requires U.S. Attorneys to give written notice of a felony conviction in federal court to the chief election official of the person’s State of residence including:

- the name of the offender
- the offender’s age and address
- the date of entry of the judgment
- a description of the relevant offense(s)
- the sentence imposed by the court

and, upon the request of the chief State or local election official, any additional information the attorney may have regarding the offender or the offense. The U.S. Attorney is required to notify the chief State election official in writing if any such conviction is overturned. Finally, the Act requires the chief State election official to convey any such information to the local registrar of the offender’s jurisdiction of residence [Section 8(g)].

The Act does not require State or local courts to provide the chief State election official with information regarding disqualifying criminal convictions; however, States that disenfranchise for certain crimes may want to consider such a provision.

Research suggests the States that require such notification be provided to the State election official on a regularly scheduled basis (e.g.; monthly) have more effective programs because reporting at the local level tends to be sporadic. The State, in turn disseminates the information to local jurisdictions either by notifying those local election officials appropriate to the addresses on the list, or by sending the entire report to all local jurisdictions.

#### ***Removal by Reason of Death***

The Act requires that States make a reasonable effort to “remove the names of ineligible voters from the official lists of eligible voters by reason of the death of the registrant...” [Section 8(a)(4)(A)]. It does not, however, specify the procedures for doing so. Because obtaining information about deaths of registrants has proved so difficult in the past, States might want to develop a more systematic approach.

One such approach might be requiring the State office in charge of vital statistics (e.g.; Bureau of Vital Statistics, Department of Health, or Division of Human Resources) to inform the chief State election official of all deaths of State residents on a monthly basis (in parallel to notices of court convictions). States may also want to establish what other sources of information about registrants who may have died are permitted and how to verify them, when necessary. These other sources may prove especially important for border jurisdictions whose registrants may seek medical attention from nearby hospitals in another State. These “unofficial” sources might include newspaper obituaries, contact with the deceased’s relatives, or personal knowledge of an employee in the office charged with administering voter registration.

#### ***Removal by Reason of a Written Confirmation of a Change of Address outside the Registrar’s Jurisdiction***

The Act prohibits removing the name of a registrant from the list of eligible voters “on the ground that the registrant has changed residence unless the registrant confirms in writing that the registrant has changed residence to a place outside the registrar’s jurisdiction in which the registrant is registered...” [Section 8(d)(1)(A)].

There are three ways in which a registrar might receive such written confirmation from the registrant.

First, the registrant may spontaneously send a notice informing the registrar of their change of address outside the jurisdiction (although this is an extremely rare practice). Still, should it happen, registrars need obtain no further confirmation.

The second way includes any actions by the registrant “that result in the registrant being registered at a new address, such as registering in another jurisdiction or providing a change-of-address notice through the driver’s license [or agency] process that updates the voter registration” [Hse. Rpt., Section 8, page 14]. This suggests that cancellation notices received from voter registrars in other jurisdictions would be sufficient for removing a registrant’s name. And by the same token, notices received from motor vehicle departments and agencies regarding a registrant’s

change of address for voting purposes to a location outside the registrar's jurisdiction would appear sufficient for removing a registrant's name. The reasoning here appears to be that registrars need obtain no further confirmation in these instances because the registrants initiate such actions or notices and, unless they specifically declare to the contrary, are indicating that the change applies to voter registration. Registrars might want to have, or at least have access to, the registrant's original signature on such notices.

The third way in which registrars might obtain written confirmation of a registrant's change of address to a location outside the registrar's jurisdiction is in response to the "confirmation" mailing described later in this chapter and in Section 8(d)(2) of the Act.

Briefly (though it is described in greater detail below), the confirmation process permits registrars to initiate a mailing to any registrant whom the registrar has legitimate reason to believe has changed address. These reasons must be uniformly applied to all registrants but may include any change-of-address information supplied by the Postal Service either through their National Change of Address files or else through their return of any election mailing (such as the acknowledgment notice described above, sample ballots, or the like) [Hse. Rpt., Section 8, pages 15 and 16]. Reasons may also include information from the courts regarding returned jury duty notices or information on driver's licenses surrendered in other states.

The reasoning here appears to be that because this kind of change-of-address information is second hand, rather than originating from the registrant, the election official must seek to confirm it directly with the registrant. This is done by sending a forwardable mailing to registrants that contains a postage prepaid and pre-addressed return notice on which registrants state their current address. If registrants return the notice confirming an address outside the registrar's jurisdiction, their names can then be removed from the voter registration file. (It should also be noted that a record of such transactions must be maintained as explained in Chapter 7). If registrants do not return the notice, then registrars must follow the procedure described immediately below.

***Removal for Failure to Respond to Certain Confirmation Mailings and Failure to Offer to Vote in Any Election within Two Subsequent General Federal Elections***

The Act provides for two types of confirmation notices. The content and format of both types of notices are addressed in more detail at the end of this chapter. The first type is sent when the Postal Service provides information that the registrant may have moved *within* the jurisdiction [Section 8(c)(1)(B)(i)]. This notice is discussed further in the next section of this chapter.

The second type of notice is sent when there is an indication that the registrant may no longer live in the registrar's jurisdiction [Section 8(d)(2)]. The Act provides that names of registrants may be removed from the voter registration list if they:

- fail to respond to the *second* type of notice (i.e.; sent because there was an indication that the registrant no longer resides in the registrar's jurisdiction); *and*
- have not voted or appeared to vote "in an election during the period beginning on the date of the notice and ending on the day after the date of the second general election for Federal office that occurs after the date of the notice" [Section 8(d)(1)(B)].

*Both* conditions (failure to respond to the second type of notice and failure to appear to vote) are required for removal.

(NOTE: If registrants fail to respond to such a confirmation mailing, they may be placed in an "Inactive" status as explained in Administering the File Maintenance Program at the end of this chapter. Moreover, records of all confirmation mailings and responses must be maintained as explained in Chapter 7.)

This procedure allows for the possibility that the change-of-address information received second hand was in error, the possibility that the registrant did not receive (or take notice of) the confirmation mailing, and the possibility that the registrant may be one of those "presidential voters" who vote only once every four years. Even if all three possibilities pertain, the registrant's right to vote is still preserved.

### **The Rule for Changing a Registrant's Address Information**

The rule for changing a registrant's address information pertains, of course, only to changes of address *within* the registrar's jurisdiction (since if they are changes of address outside the registrar's jurisdiction, registrants will be removed from the voter registration list according to one of the two procedures outlined immediately above).

The Act provides that "In case of a change of address, for voting purposes, of a registrant to another address within the same registrar's jurisdiction, the registrar shall correct the voting registration list accordingly, and the registrant's name may not be removed from the official list of eligible voters except [when the individual confirms in writing that he or she no longer resides in the jurisdiction, or fails to respond to a Section 8(d)(2) notice and fails to vote or appear to vote in an election within a period up to the second general federal election after that notice] [Section 8(f)].

There are at least five ways in which a registrar might receive information about a registrant's change of address within the jurisdiction.

First, the registrant may spontaneously send a note (or a mail registration form) informing the registrar of their move. Should that happen, the registrar need not seek further confirmation before changing the registrant's address in the voter registration file. And although the law does not specifically require it, it would seem appropriate to inform the registrant of this action as well as of the location of the registrant's polling place.

The second way is if the registrant files a change-of-address notice with the motor vehicle office or through an agency designated to register voters under the Act, unless the registrant declares that the change of address is not for voting purposes. Because these notices are also initiated by the registrant, the registrar need not seek further confirmation before changing the registrant's address on the voter registration list (and, presumably, sending an appropriate notice to the registrant).

The third way in which registrars may learn of a registrant's change of address within their jurisdiction is through information provided by the Postal Service either through the National Change of Address program or else upon return of any election mailing.

"[I]f it appears from information provided by the Postal Service that a registrant has moved to a different residence address in the same registrar's jurisdiction in which the registrant is currently registered, the registrar changes the registration records to show the new address and sends the registrant a notice of the change by forwardable mail and a postage prepaid pre-addressed return form by which the registrant may verify or correct the address information" [Section 8(c)(1)(B)(i)].

(NOTE: Even if registrants who have moved within the jurisdiction fail to respond to this type of confirmation mailing, they should *not* be designated as inactive and cannot be removed from the registration list. Moreover, records of all confirmation mailings and responses must be maintained as explained in Chapter 7.)

The reasoning behind this procedure appears to be that because Postal Service change-of-address information is second hand, rather than originating from the registrant, the election official must seek direct, first-hand confirmation.

The fourth way in which registrars might obtain written confirmation of a registrant's change of address to a location within the registrar's jurisdiction is through responses to one of the two confirmation notices described earlier in this chapter and in Sections 8(c)(1)(B)(i) and 8(d)(2) of the Act.

The fifth way in which registrars may learn of a change of address within the jurisdiction is through changes of address made by registrants at the polls on election day. (See Fail-Safe Voting Provisions in Chapter 6.)

### **Administering the File Maintenance Program**

Important aspects of administering a voter registration list maintenance program include:

- the need to ensure uniformity and compliance with the Voting Rights Act of 1965, as amended
- addressing confirmation notices

- monitoring “inactive” voters
- identifying duplicate registrations
- the deadline for completing list maintenance activities
- the accountability of list maintenance activities
- the need to appoint someone to be in charge of list maintenance activities, and
- the need to train local registration officials.

#### *Ensuring Uniformity and Compliance with the Voting Rights Act*

The Act specifies that “Any State program or activity to protect the integrity of the electoral process by ensuring the maintenance of an accurate and current voter registration role ... shall be uniform, nondiscriminatory, and in compliance with the Voting Rights Act of 1965 (42 U.S.C. 1973 et seq.)” [Section 8(b)(1)].

According to the House, “This requirement may not be avoided by a registrar conducting a purge program or activity based on lists provided by other parties where such lists were compiled as the result of a selective non-uniform, or discriminatory program or activity.” Also, the requirement effects “any activity that is used to start, or has the effect of starting a purge of the voter rolls, without regard to how it is described or to whether it also may have some other purpose. For example, the mailing of sample ballots is clearly a program that has another purpose but might provide the basis for a remove of voter rolls.” [Hse. Rpt., page 15].

The Senate expanded on this concern by noting that list maintenance programs “must be scrutinized to prevent poor and illiterate voters from being caught in a purge system which will require them to needlessly reregister. Such processes must be structured to prevent abuse which has a disparate impact on minority communities” [Sen. Rpt., page 18].

The National Voter Registration Act of 1993 is specifically intended to be complementary to rather than contradictory to the Voting Rights Act of 1965. Section 11(d)(1) states, in part, that “neither the rights and remedies established by this section nor any other provision of this Act shall supersede, restrict, or limit the application of the Voting Rights Act of 1965 (42 U.S.C. 1973 et seq.)”. Section 11(d)(2) states “Nothing in this Act authorizes or requires conduct that is prohibited by the Voting Rights Act of 1965 (42 U.S.C. 1973 et seq.)”. The Senate notes that “Merely because a program was conducted under the National Voter Registration Act would not be a defense to any claim which might be asserted under the Voting Rights Act ... The States must comply with the National Voter Registration Act in a manner which does not violate the Voting Rights Act” [Sen. Rpt., page 18].

States should note that Section 2 of the Voting Rights Act applies to all States and prohibits any State or political subdivision from imposing or applying election laws

or procedures which discriminate against individuals on account of race, color, or language minority status [42 U.S.C. 1973]. It follows, then, that whatever list maintenance procedures that States adopt, they must be nondiscriminatory in both intent and effect.

Furthermore, those jurisdictions that are subject to the preclearance or bilingual requirements of the Voting Rights Act must continue to adhere to these provisions when implementing the NVRA voter list maintenance provisions.

Finally, the removal of the names of registrants who were registered by federal examiners under the U.S. Office of Personnel Management (OPM), in accordance with 42 U.S.C. 1973d, would be subject to the same restrictions as established prior to the NVRA (i.e.; approval must be obtained from OPM before such names can be deleted from the rolls).

#### *Addressing Confirmation Notices*

Although the Act requires that confirmation mailings be sent to registrants "by forwardable mail" [Sections 8(c)(1)(B)(i) and 8(d)(2)], it does not specify to which address these mailings should be sent. In some cases (such as when a mailing to a registrant has been returned as undeliverable with no forwarding address), the registrar will have only one address. In other cases, however, (such as when notified by the Postal Service of a change of address), the registrar will have a choice of mailing to the old address on file, to the new address provided by the Postal Service, or to both.

When faced with a choice, the advantage in mailing to the old address is that those registrants who have *not* permanently changed address may receive it at the old address and have an opportunity to respond accordingly (whereas they would not receive the mailing if it were sent to the new address). A disadvantage to using the old address is that if the registrant has moved, the notice may not be received through postal forwarding — since most local post offices retain change-of-address records for only 12 or 18 months.

The advantages and disadvantages of mailing to the new address are almost the reverse. If the registrant has moved, the notice will probably be received. If the new address is in error, the registrant would never receive it.

These problems can be overcome if notices are mailed to both addresses, but at the cost of increased printing and postage for the production and mailing of additional mailings plus the potential of voter confusion at receiving both mailings.

States may want to consider establishing a consistent statewide procedure for addressing confirmation mailings.

#### *Monitoring "Inactive" Voters*

The Act does not prohibit designating as "inactive" those voters who have not responded to a confirmation mailing that was sent in accordance with Section 8(d)(2)